



Auxiliary Care Radar

User Manual

Legal Information

About this Document

- This Document includes instructions for using and managing the Product. Pictures, charts, images and all other information hereinafter are for description and explanation only.
- The information contained in the Document is subject to change, without notice, due to firmware updates or other reasons. Please find the latest version of the Document at the Hikvision website (<https://www.hikvision.com>). Unless otherwise agreed, Hangzhou Hikvision Digital Technology Co., Ltd. or its affiliates (hereinafter referred to as "Hikvision") makes no warranties, express or implied.
- Please use the Document with the guidance and assistance of professionals trained in supporting the Product.

About this Product

This product can only enjoy the after-sales service support in the country or region where the purchase is made.

Acknowledgment of Intellectual Property Rights

- Hikvision owns the copyrights and/or patents related to the technology embodied in the Products described in this Document, which may include licenses obtained from third parties.
- Any part of the Document, including text, pictures, graphics, etc., belongs to Hikvision. No part of this Document may be excerpted, copied, translated, or modified in whole or in part by any means without written permission.
- **HIKVISION** and other Hikvision's trademarks and logos are the properties of Hikvision in various jurisdictions.
- Other trademarks and logos mentioned are the properties of their respective owners.

LEGAL DISCLAIMER

- TO THE MAXIMUM EXTENT PERMITTED BY APPLICABLE LAW, THIS DOCUMENT AND THE PRODUCT DESCRIBED, WITH ITS HARDWARE, SOFTWARE AND FIRMWARE, ARE PROVIDED "AS IS" AND "WITH ALL FAULTS AND ERRORS". HIKVISION MAKES NO WARRANTIES, EXPRESS OR IMPLIED, INCLUDING WITHOUT LIMITATION, MERCHANTABILITY, SATISFACTORY QUALITY, OR FITNESS FOR A PARTICULAR PURPOSE. THE USE OF THE PRODUCT BY YOU IS AT YOUR OWN RISK. IN NO EVENT WILL HIKVISION BE LIABLE TO YOU FOR ANY SPECIAL, CONSEQUENTIAL, INCIDENTAL, OR INDIRECT DAMAGES, INCLUDING, AMONG OTHERS, DAMAGES FOR LOSS OF BUSINESS PROFITS, BUSINESS INTERRUPTION, OR LOSS OF DATA, CORRUPTION OF SYSTEMS, OR LOSS OF DOCUMENTATION, WHETHER BASED ON BREACH OF CONTRACT, TORT (INCLUDING NEGLIGENCE), PRODUCT LIABILITY, OR OTHERWISE, IN CONNECTION WITH THE USE OF THE PRODUCT, EVEN IF HIKVISION HAS BEEN ADVISED OF THE POSSIBILITY OF SUCH DAMAGES OR LOSS.
- YOU ACKNOWLEDGE THAT THE NATURE OF THE INTERNET PROVIDES FOR INHERENT SECURITY RISKS, AND HIKVISION SHALL NOT TAKE ANY RESPONSIBILITIES FOR ABNORMAL OPERATION,



PRIVACY LEAKAGE OR OTHER DAMAGES RESULTING FROM CYBER-ATTACK, HACKER ATTACK, VIRUS INFECTION, OR OTHER INTERNET SECURITY RISKS; HOWEVER, HIKVISION WILL PROVIDE TIMELY TECHNICAL SUPPORT IF REQUIRED.

- YOU AGREE TO USE THIS PRODUCT IN COMPLIANCE WITH ALL APPLICABLE LAWS, AND YOU ARE SOLELY RESPONSIBLE FOR ENSURING THAT YOUR USE CONFORMS TO THE APPLICABLE LAW. ESPECIALLY, YOU ARE RESPONSIBLE, FOR USING THIS PRODUCT IN A MANNER THAT DOES NOT INFRINGE ON THE RIGHTS OF THIRD PARTIES, INCLUDING WITHOUT LIMITATION, RIGHTS OF PUBLICITY, INTELLECTUAL PROPERTY RIGHTS, OR DATA PROTECTION AND OTHER PRIVACY RIGHTS. YOU SHALL NOT USE THIS PRODUCT FOR ANY PROHIBITED END-USES, INCLUDING THE DEVELOPMENT OR PRODUCTION OF WEAPONS OF MASS DESTRUCTION, THE DEVELOPMENT OR PRODUCTION OF CHEMICAL OR BIOLOGICAL WEAPONS, ANY ACTIVITIES IN THE CONTEXT RELATED TO ANY NUCLEAR EXPLOSIVE OR UNSAFE NUCLEAR FUEL-CYCLE, OR IN SUPPORT OF HUMAN RIGHTS ABUSES.
- IN THE EVENT OF ANY CONFLICTS BETWEEN THIS DOCUMENT AND THE APPLICABLE LAW, THE LATTER PREVAILS.

© Hangzhou Hikvision Digital Technology Co., Ltd. All rights reserved.

Symbol Conventions

The symbols that may be found in this document are defined as follows.

Symbol	Description
 Danger	Indicates a hazardous situation which, if not avoided, will or could result in death or serious injury.
 Caution	Indicates a potentially hazardous situation which, if not avoided, could result in equipment damage, data loss, performance degradation, or unexpected results.
 Note	Provides additional information to emphasize or supplement important points of the main text.

Contents

Chapter 1 Overview	1
1.1 Introduction	1
1.2 Key Features	1
1.3 Specifications	1
1.4 Appearance	2
1.5 Typical Application	4
Chapter 2 Installation	5
2.1 Installation Environment	5
2.2 Installation Preparation	5
2.3 Installation	6
Chapter 3 Device Activation and Accessing	8
3.1 Activate the Device via SADP	8
3.2 Activate the Device via Browser	8
3.3 Login and Logout via Web	9
Chapter 4 Web Operation	10
4.1 Vital Sign Monitoring	10
4.1.1 Rader Information	10
4.1.2 Basic Settings	10
4.1.3 Event Settings	11
4.1.4 Current Status	12
4.2 System Configuration	13
4.2.1 Basic Information	13
4.2.2 Device Status	14
4.2.3 Time Settings	15
4.2.4 DST	15
4.2.5 Indicator	16
4.2.6 Maintenance	16
4.3 Network Configuration	17
4.3.1 Network Interface	17

4.3.2 Wi-Fi	18
4.4 Data Connection Configuration	19
4.4.1 OTAP	19
Chapter 5 Device Maintenance	21
Chapter 6 FAQ (Frequently Asked Question)	22
6.1 Question 1	22
6.2 Question 2	22
6.3 Question 3	22
6.4 Question 4	22
6.5 Question 5	22
6.6 Question 6	23
6.7 Question 7	23
6.8 Question 8	23
6.9 Question 9	23
6.10 Question 10	23
6.11 Question 11	23
6.11 Question 12	24
6.13 Question 13	24
6.14 Question 14	24

Chapter 1 Overview

1.1 Introduction

Auxiliary care radar is a millimeter-wave radar for vital sign detection based on the 60 GHz frequency band. The radar adopts the FMCW system, and comprehensively uses MIMO, beamforming, micro-Doppler feature extraction and other technologies to realize the detection of vital signs such as absence, respiration, heartbeat, etc.

It can be installed at the head of the bed to provide non-contact coverage of the bed area, and it obtains the information such as the time in the bed, the time out of the bed, respiratory rate, heart rate, body movement times, etc., so as to assist in the analysis of human sleep quality and health status. Besides, it also has two-way voice intercom and emergency rope pull alarm functions.

1.2 Key Features

The device has following key features:

- Adopts millimeter-wave radar detection without visual sense, no privacy disclosure.
- All-weather detection without the influence of illumination and temperature.
- Supports outputting information of whether the human body is in the bed or not.
- Supports outputting information of respiratory rate, heart rate, etc., in real-time.
- Supports two-way voice intercom function.
- Supports emergency rope pull alarm function.

1.3 Specifications

Table 1-1 Specifications

Parameter	Auxiliary Care Radar
Working Frequency	60 GHz to 64 GHz
Modulation Waveform	FMCW
Detection Distance	0.5 m to 1.5 m
Scan Bandwidth	3.5 GHz
Distance Resolution	0.0435 m
Horizontal Detection Angle	-25° to 25°
Vertical Detection Angle	-10° to 10°
Data Period	50 ms
Power Input	9 VDC to 12 VDC, or PoE power supply
Working Current	≤ 220 mA @12 VDC

Parameter	Auxiliary Care Radar
Power Consumption	≤ 2.64 W
Alarm Output	Switch volume (without voltage)
Communication Interface	Wi-Fi (2.4 G frequency band)/PoE
Communication Protocol	OTAP protocol
Working Temperature	-40 °C to 50 °C (-40 °F to 122 °F)
Dimensions	96 mm × 96 mm × 65 mm (3.8" × 3.8" × 2.6") (L × W × H)

1.4 Appearance

- Rope: It is used to trigger alarm function.
- Button: It has three functions:
 - Trigger voice intercom.
 - Long press it for 5 sec and release the button when the indicator flashes slowly, and the Wi-Fi hotspot function is enabled.
 - Press and hold for 15 sec until the indicator light flashes rapidly. Release the button while the indicator is flashing rapidly to restore factory settings.
- Dimensions: 96 mm × 96 mm × 65 mm, including bracket.



Figure 1-1 Appearance

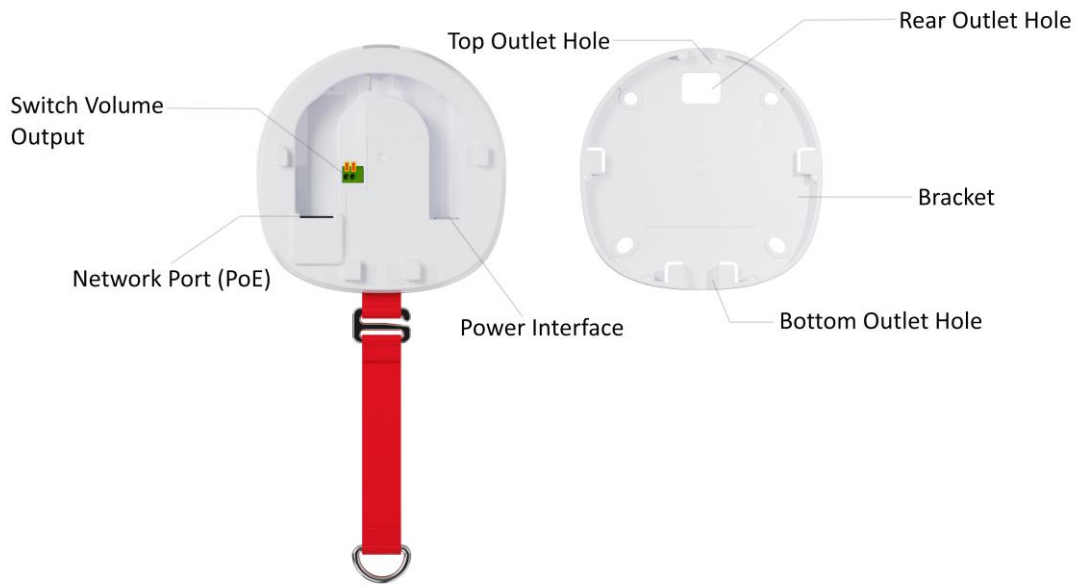

Figure 1-2 Component

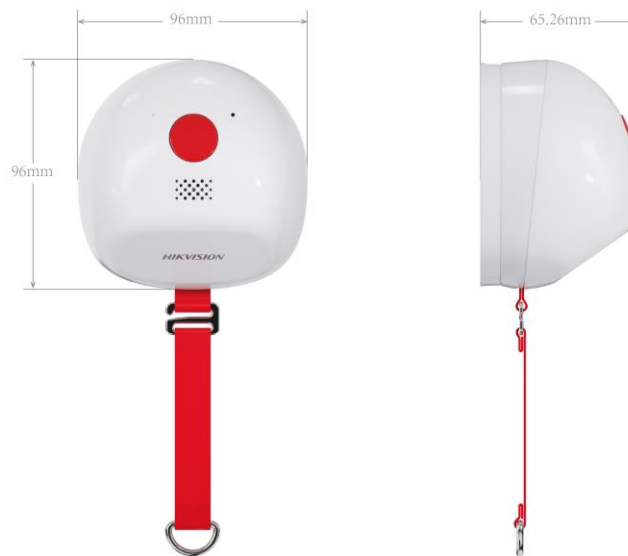

Figure 1-3 Dimensions

1.5 Typical Application

- Installation height: 0.5 m to 1.2 m above the bed.
- Coverage area: 1.5-meter width single bed.



Figure 1-4 Typical Application

Chapter 2 Installation

2.1 Installation Environment

- The device only supports side installation, fixed on the wall of the head of the bed, and the installation height from the bed is 50 cm to 120 cm, and it is recommended to install 100 cm.
- The device is mainly used in single-person scenarios, please make sure that there is no obstruction between the device and the bed.

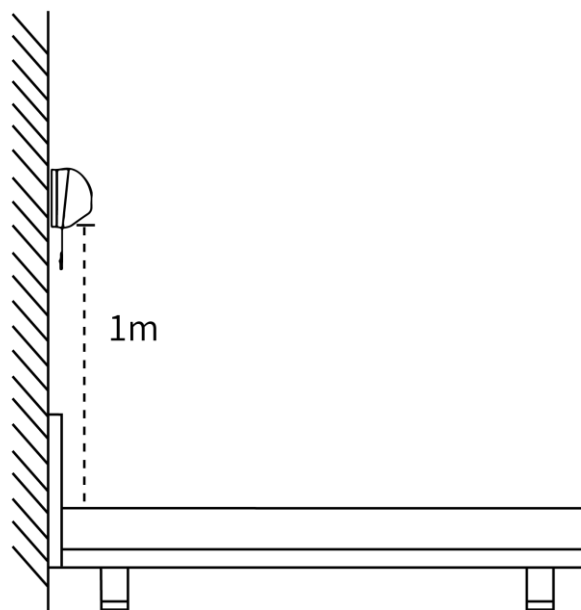

Figure 2-1 Installation Environment

2.2 Installation Preparation

Before You Start

- Before installation, please prepare the hammer, network cable and accessories that come with the device.
- Before installation, please confirm that the device and accessories in the package are complete.
- Please pre-deploy the power cord.

2.3 Installation

Steps

1. Select a suitable location according to the installation instructions.
2. Install the bracket.

Note

The bracket supports three installation methods: 3M double-sided tape sticking fixing, steel nail fixing, or expansion screw fixing.

- 3M double-sided tape sticking fixing: Paste one side of the 3M double-sided tape on the back of the bracket, and the other side to the position to be installed, fix the bracket, and press for at least 30 seconds.

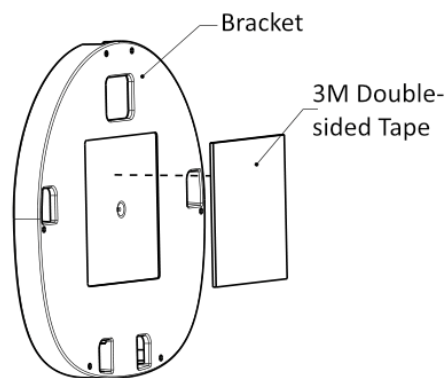

Figure 2-2 3M Double-sided Tape Sticking Fixing

- Steel nail fixing: Use steel nails that come with the device, pass through the fixing holes on the bracket and fix the bracket in the position to be installed.

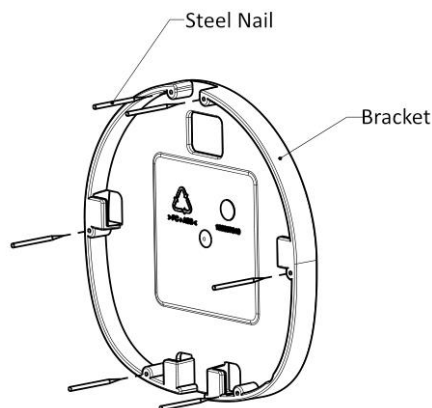

Figure 2-3 Steel Nail Fixing

- Expansion screw fixing: Use the expansion screw that comes with the device, pass through the fixing hole on the bracket, and fix the bracket in the position to be installed.

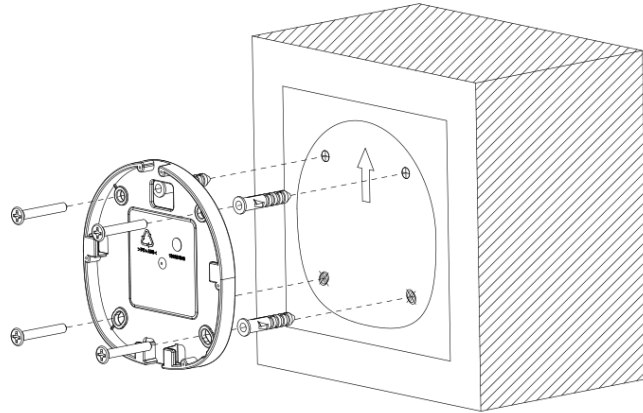

Figure 2-4 Expansion Screw Fixing

3. Connect the power cord and network cable.
4. After the bracket is fixed, align the mounting hole of the device with the bracket buckle, and pull it down and hang it tightly.

Note

- Depending on the installation environment, the wiring is routed from the rear outlet hole of the bracket, or the upper (lower) outlet hole.
 - Regarding device's installation position: After the person is lying on the bed, the device is as close as possible towards the person's chest, and the device mainly detects the chest cavity undulation.
-

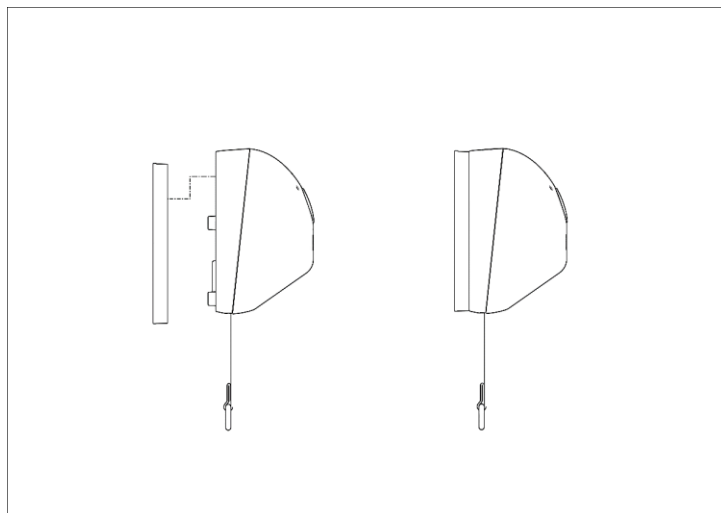

Figure 2-5 Wiring

Chapter 3 Device Activation and Accessing

3.1 Activate the Device via SADP

Search and activate the online devices via SADP software.

Before You Start

Access www.hikvision.com to get SADP software to install.

Note

The default values of the device are as follows:

- Default IP address: 192.168.1.64
 - Default username: admin
-

Steps

1. Connect the device to network using the network cable.
 2. Run SADP software to search the online devices.
 3. Check **Device Status** from the device list, and select **Inactive** device.
 4. Create and enter the new password in the password field, and confirm the password.
-

Caution

We highly recommend you create a strong password of your own choosing (using a minimum of 8 characters, including upper case letters, lower case letters, numbers, and special characters) in order to increase the security of your product. And we recommend you reset your password regularly, especially in the high security system, resetting the password monthly or weekly can better protect your product.

5. Click **OK**. **Device Status** changes into **Active**.
6. Optional: Change the network parameters of the device in **Modify Network Parameters**.

3.2 Activate the Device via Browser

You can access and activate the device via the browser.

Steps

1. Connect the device to the PC using the network cables.
2. Change the IP address of the PC and device to the same segment.

Note

The default IP address of the device is 192.168.1.64. You can set the IP address of the PC from 192.168.1.2 to 192.168.1.253 (except 192.168.1.64). For example, you can set the IP address of the PC to 192.168.1.100.

3. Enter **192.168.1.64** in the browser.
 4. Set device activation password.
-

Caution

We highly recommend you create a strong password of your own choosing (using a minimum of 8 characters, including at least three of the following categories: upper case letters, lower case letters, numbers, and special characters) in order to increase the security of your product. And we recommend you reset your password regularly, especially in the high security system, resetting the password monthly or weekly can better protect your product.

5. Click **OK**.
6. Enter the activation password to log in to the device.

3.3 Login and Logout via Web

Log in to the device via Web browser.

Steps

1. Enter the IP address of the device in the address bar of the browser, for example, `http://192.168.1.64`, and press **Enter**.
2. Enter your username and password.
3. Click **OK**.
4. Optional: If you need to exit the system safely, please click **Logout** in the upper right corner.

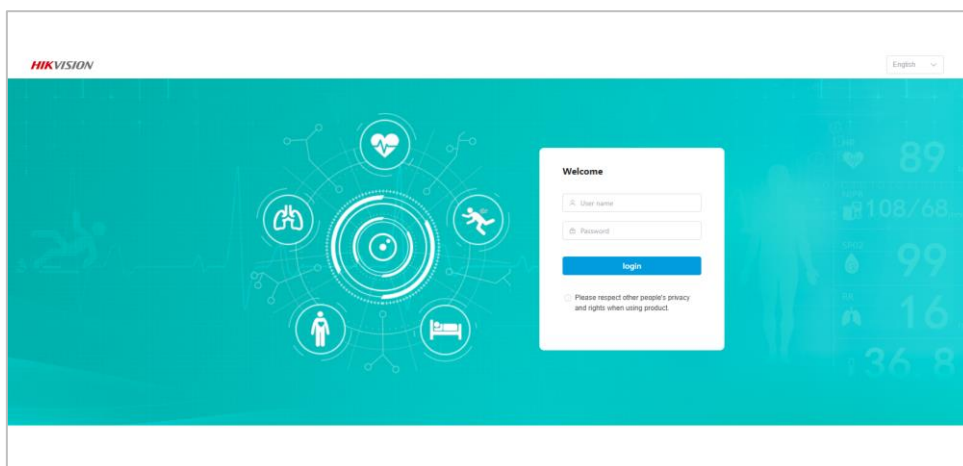

Figure 3-1 Login via Web

Chapter 4 Web Operation

4.1 Vital Sign Monitoring

In the page of vital sign monitoring, you can view and set real-time monitoring data.

4.1.1 Rader Information

You can view radar status and software version here.

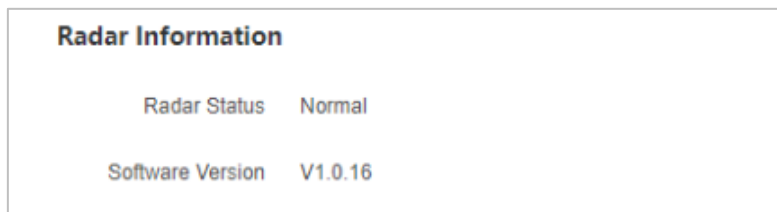

Figure 4-1 Radar Information

4.1.2 Basic Settings

- Vertical Detection Distance (cm): It is the distance between the radar and the bed. The default value is 100 cm, which can be set according to the actual installation height.
- Human Body Detection Sensitivity: It is the sensitivity of detecting whether a person is in bed. The lower the value, the less sensitive the detection is, and too low may lead to missed detection. The higher the value, the easier it is to detect the human body, but too high can lead to false detection. The setting range is 0 to 9, the default value of 6 is recommended.
- Body Moving Detection Sensitivity: It is the sensitivity of detecting whether the person is moving. The lower the value, the less sensitive the detection is, and too low may lead to missed detection. The higher the value, the easier it is to detect body movement, but too high may lead to false detection. The setting range is 0 to 9, the default value of 6 is recommended.

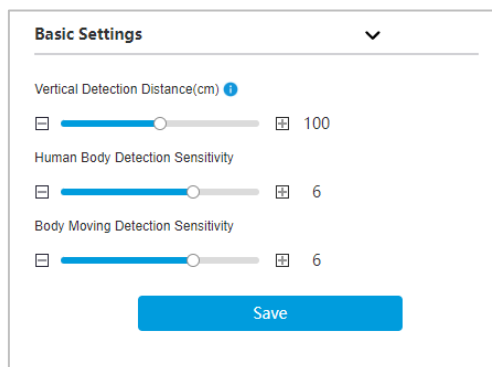

Figure 4-2 Basic Settings

4.1.3 Event Settings

You can set alarm parameters here in event settings.

- **Out-of-Bed Duration:** If a person leaves the bed for a long time for more than the configured duration, an alarm will be triggered. The unit is minute.

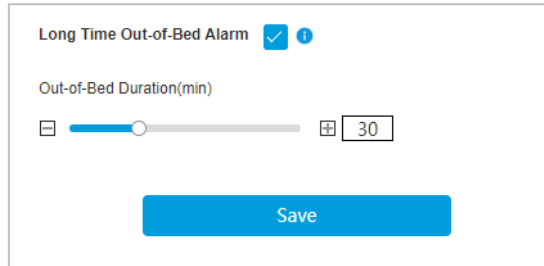

Figure 4-3 Out-of-Bed Duration

- **Abnormal Respiration/Heart Rate Alarm**

There are six types of alarm events: Abnormal high heart rate, abnormal low heart rate, sudden change heart rate, abnormal high respiration rate, abnormal low respiration rate, and sudden change respiration rate.

- **Abnormal High Heart Rate/Low Heart Rate:** If the heart rate is consistently higher or lower than the specified threshold, and the duration exceeds the specified threshold, an alarm is generated.

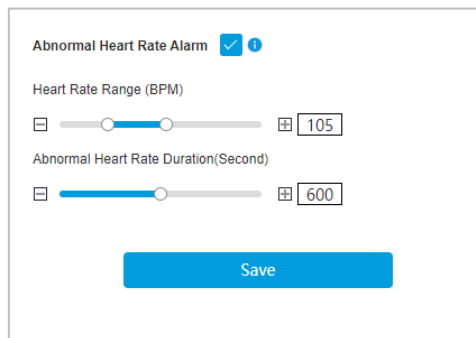

Figure 4-4 Abnormal Heart Rate Alarm

- **Sudden Change Heart Rate:** Within the configured period of time (Sudden Change Heart Rate Duration), the heart rate changes to the configured threshold (Sudden Change Heart Rate Times), and an alarm is generated.

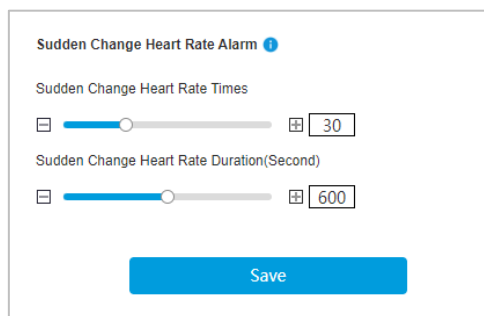
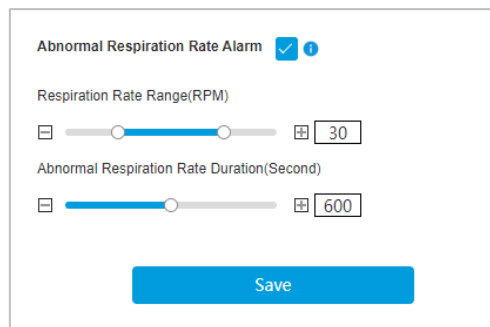

Figure 4-5 Sudden Change Heart Rate

- Abnormal High Respiration Rate/Low Respiration Rate: If the respiration rate persistently higher or lower than the specified threshold, and the respiration rate exceeds the specified threshold, an alarm is generated.



Abnormal Respiration Rate Alarm ⓘ

Respiration Rate Range(RPM)

Abnormal Respiration Rate Duration(Second)

Save

Figure 4-6 Abnormal Respiration Rate Alarm

- Sudden Change Respiration Rate: Within a set period of time (Sudden Change Respiration Rate Duration), the respiration rate changes to the configured threshold (Sudden Change Respiration Rate Times), and an alarm is generated.

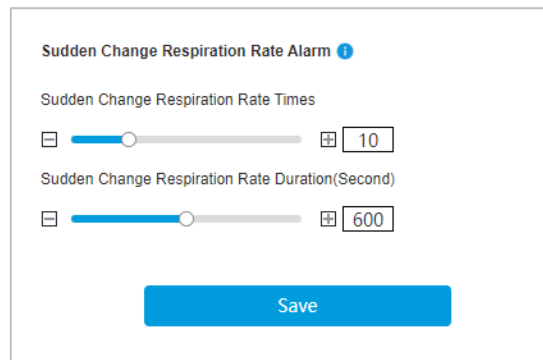

Sudden Change Respiration Rate Alarm ⓘ

Sudden Change Respiration Rate Times

Sudden Change Respiration Rate Duration(Second)

Save

Figure 4-7 Sudden Change Respiration Rate

4.1.4 Current Status

In current status page, you can view a person's in bed and out-of-bed duration, and movement times.

- Out of Bed Duration: The duration of the person's absence from the bed.
- In Bed Duration: How long the person has been in bed.
- Movement: The number of body movements.
- Range of Instantaneous Breathing Rate/Heart Rate: The time-domain waveform calculated by detecting the fluctuation of the human chest cavity can display the breathing/heartbeat amplitude in real time.
- Breathing Rate: The number of human breaths per minute detected.
- Heart Rate: The number of heartbeats per minute of the detected human body.

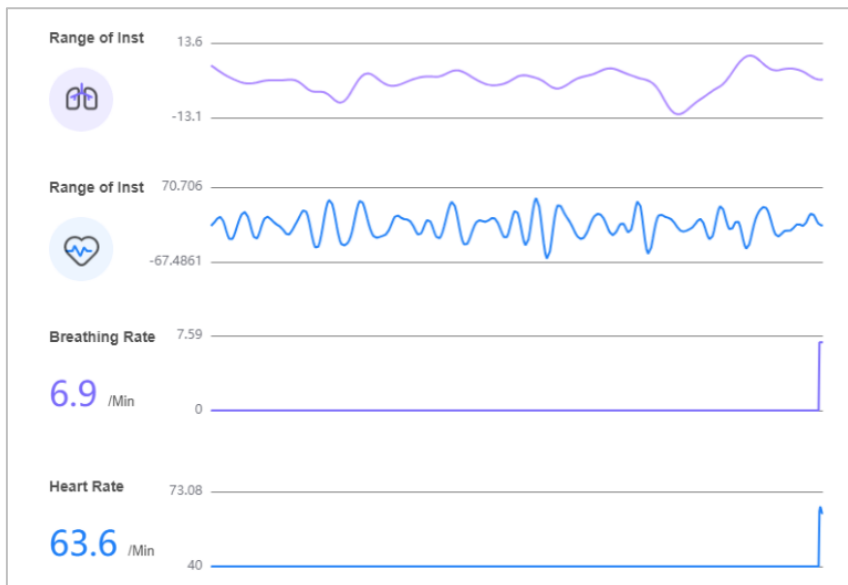

Figure 4-8 Current Status

- Real-Time Abnormal Event: Abnormal heart rate events, abnormal breathing events, long-term bed-leaving events without returning, rope pull emergency alarms, bed-going events, and bed-leaving events.

Real-Time Abnormal Event			
No.	Alarm Event	Vital Sign Data	Time

Figure 4-9 Real-Time Abnormal Event

4.2 System Configuration

In system configuration page, you can view and configure the device’s basic information, status, time, DST, indicator, and maintenance information.

4.2.1 Basic Information

Go to **Configuration** → **System** → **System Settings** → **Basic Information**, and you can edit the device’s name, and view its type, serial number, firmware version, hardware version, and web version.

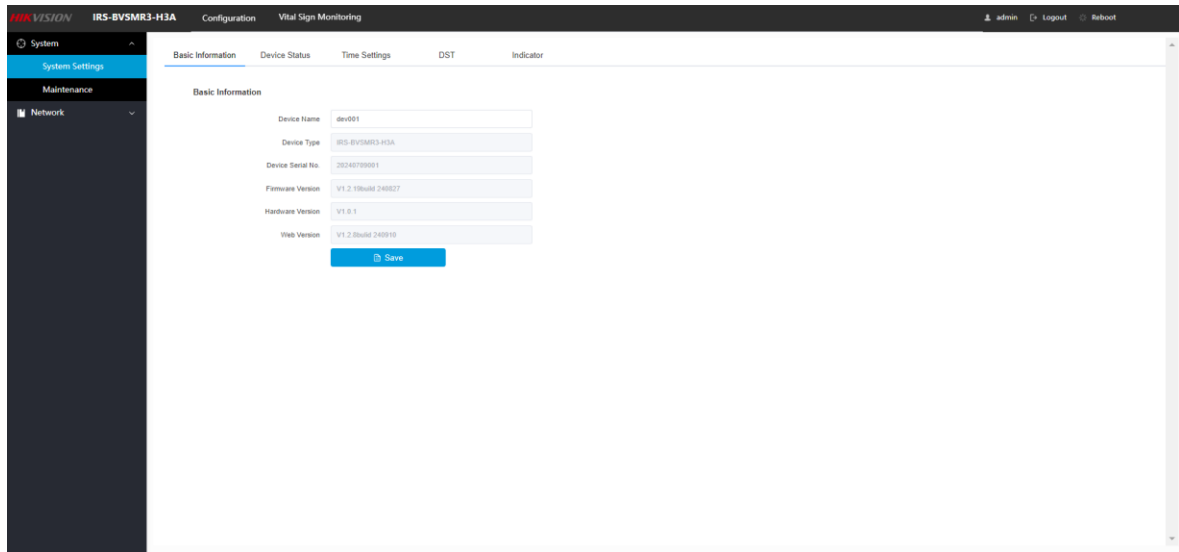

Figure 4-10 Basic Information

4.2.2 Device Status

Go to **Configuration** → **System** → **System Settings** → **Device Status**, and you can view the device's CPU usage, used memory, available memory, memory utilization, current time, and running time.

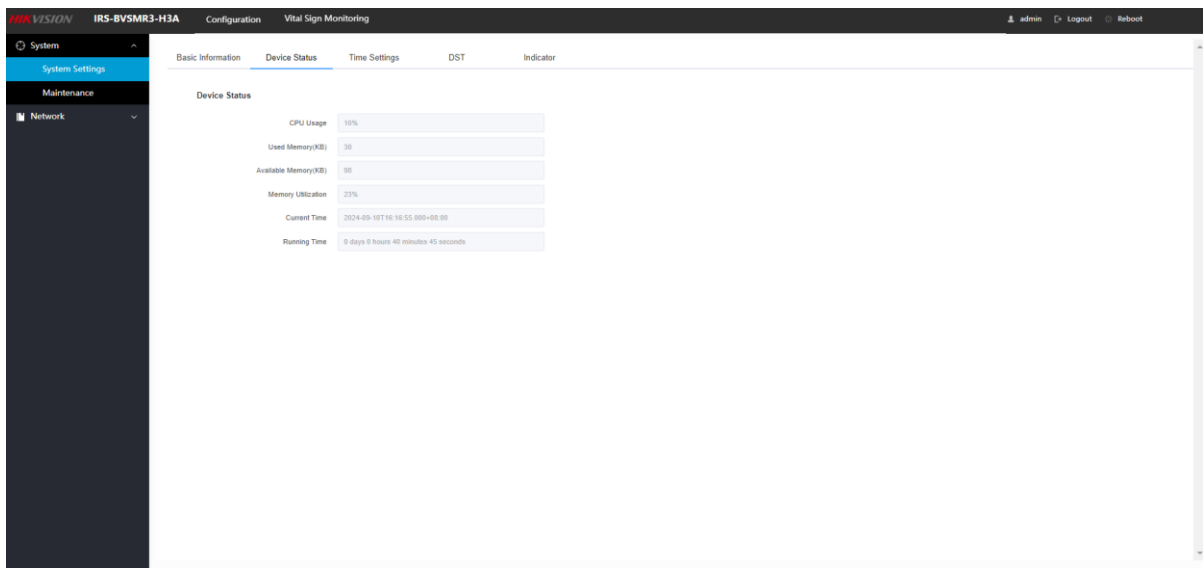

Figure 4-11 Device Status

4.2.3 Time Settings

Go to **Configuration** → **System** → **System Settings** → **Time Settings**, and you can set time zone, select time sync. mode, view and set the device's time.

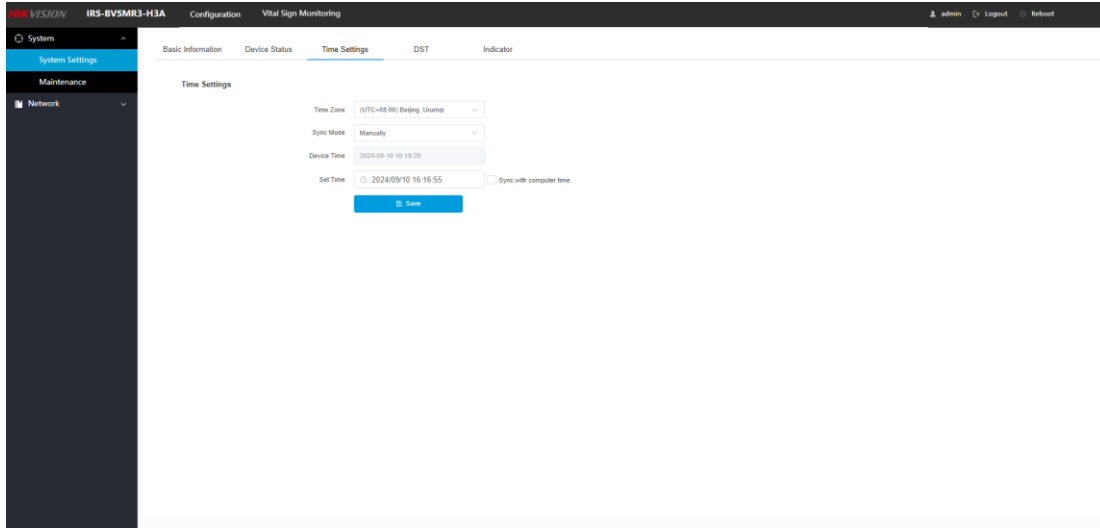

Figure 4-12 Time Settings

4.2.4 DST

If the region where the device is located adopts Daylight Saving Time (DST), you can set this function.

Steps

1. Go to **Configuration** → **System** → **System Settings** → **DST**.
2. Check **Enable DST**.
3. Select **Start Time**, **End Time** and **DST Bias**.
4. Click **Save**.

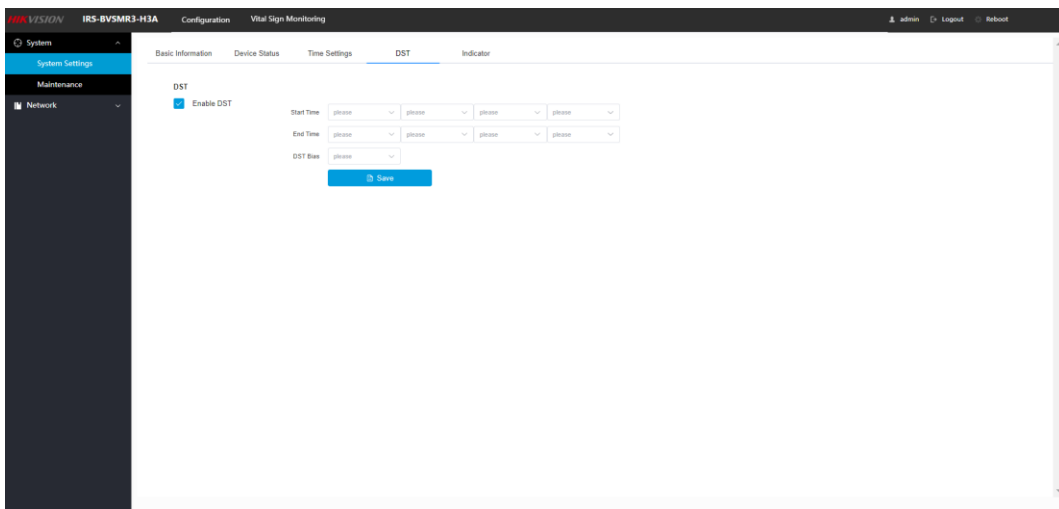

Figure 4-13 DST

4.2.5 Indicator

Go to **Configuration** → **System** → **System Settings** → **Indicator**, and you can set the device's indicator.

- **Automatic Switch:** The indicator changes automatically according to the connection network status, the indicator turns on when connected to the server, and the indicator turns off when the server is disconnected.
- **Manual Switch:** It manually sets the indicator's status, turn on and off according to the **Turn On/Off Light Manually**.

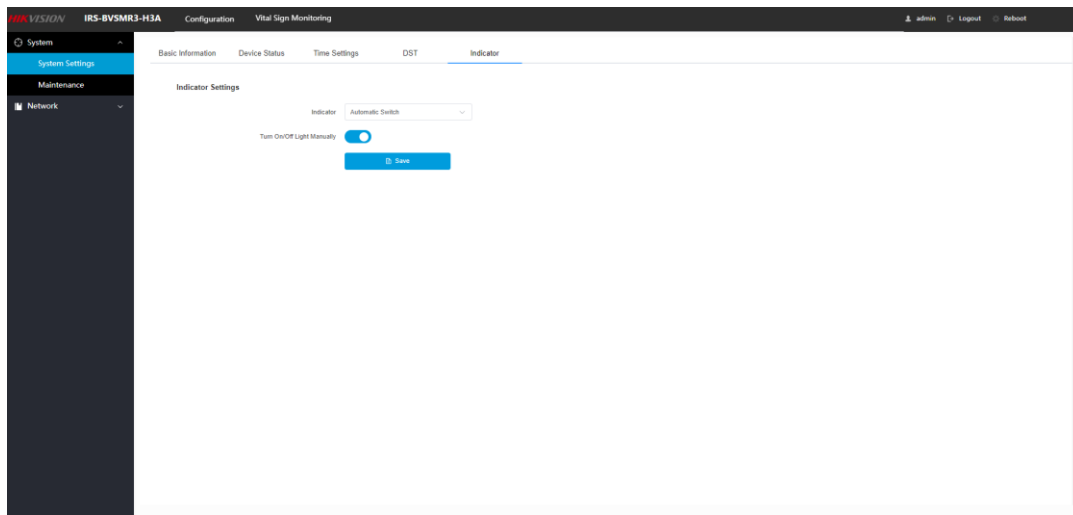

Figure 4-14 Indicator

4.2.6 Maintenance

Go to **Configuration** → **System** → **Maintenance** → **Upgrade & Maintenance**, and you can reboot the device, restore it to factory settings, export device data, and upgrade the device.

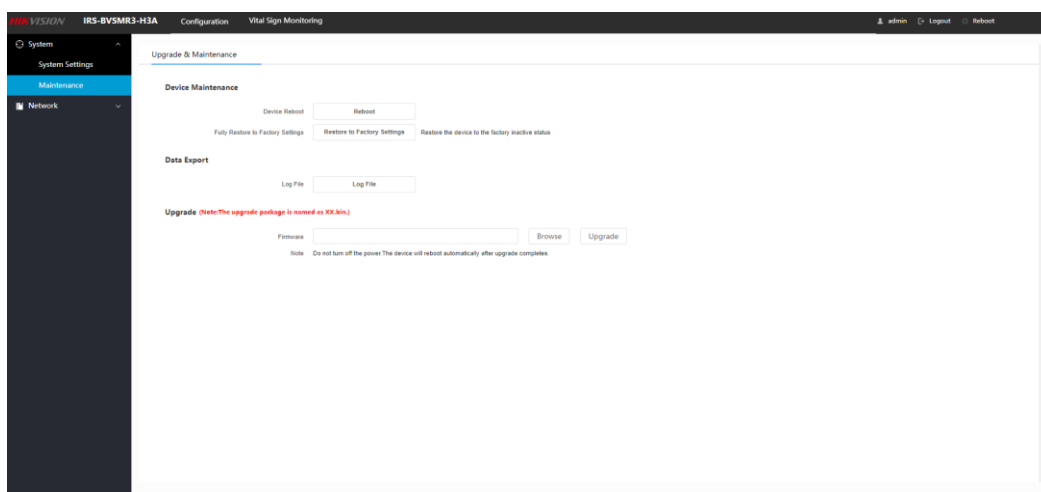

Figure 4-15 Maintenance

4.3 Network Configuration

In network configuration page, you can configure network parameters, OTAP parameters, etc.

4.3.1 Network Interface

Go to **Configuration** → **Network** → **Network Parameters** → **Network Interface** for parameter settings.

- **DHCP**: The device automatically gets the IPv4 parameters from the network if you check **DHCP**. The device IP address is changed after enabling the function. You can use SADP to get the device IP address.
- **Manual**: If you do not check **DHCP**, you can set the device IPv4 parameters manually. Input **IPv4 Address**, **IPv4 Subnet Mask**, and **IPv4 Default Gateway**.

Note

- The network that the device is connected to should support DHCP (Dynamic Host Configuration Protocol).
 - Click **Save** after parameter settings.
-

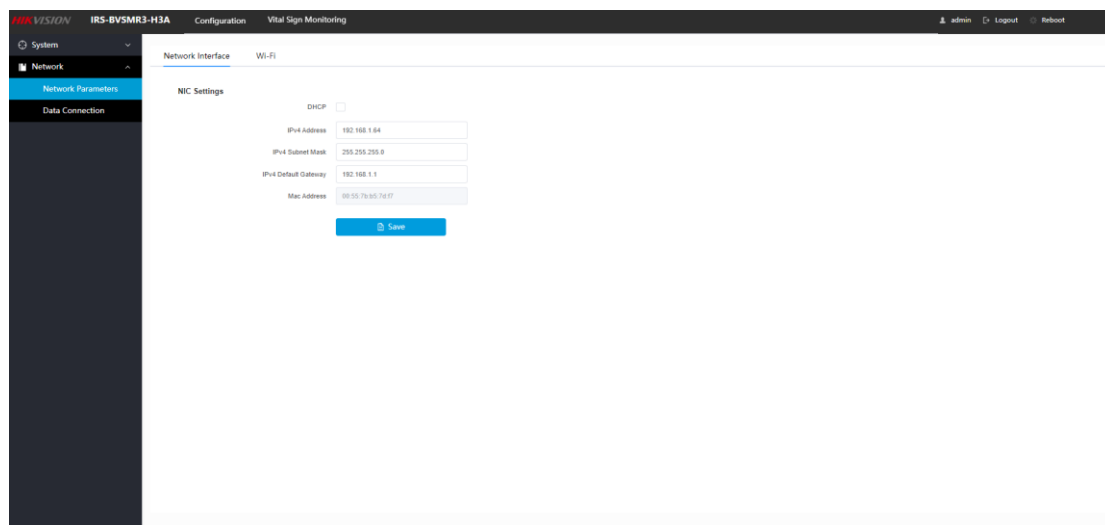

Figure 4-16 Network Interface

4.3.2 Wi-Fi

In Wi-Fi configuration page, you can configure Wi-Fi and Wi-Fi hotspot parameters, and check its status.

Set Wi-Fi

You need to configure Wi-Fi parameters if the device accesses to the network via Wi-Fi.

Steps

1. Go to **Configuration** → **Network** → **Network Parameters** → **Wi-Fi** for parameter settings.
2. Check **Wi-Fi** and enter **SSID** and **Key**, and click **Save**.
3. Select **IP Address Type**, and enter corresponding parameters.

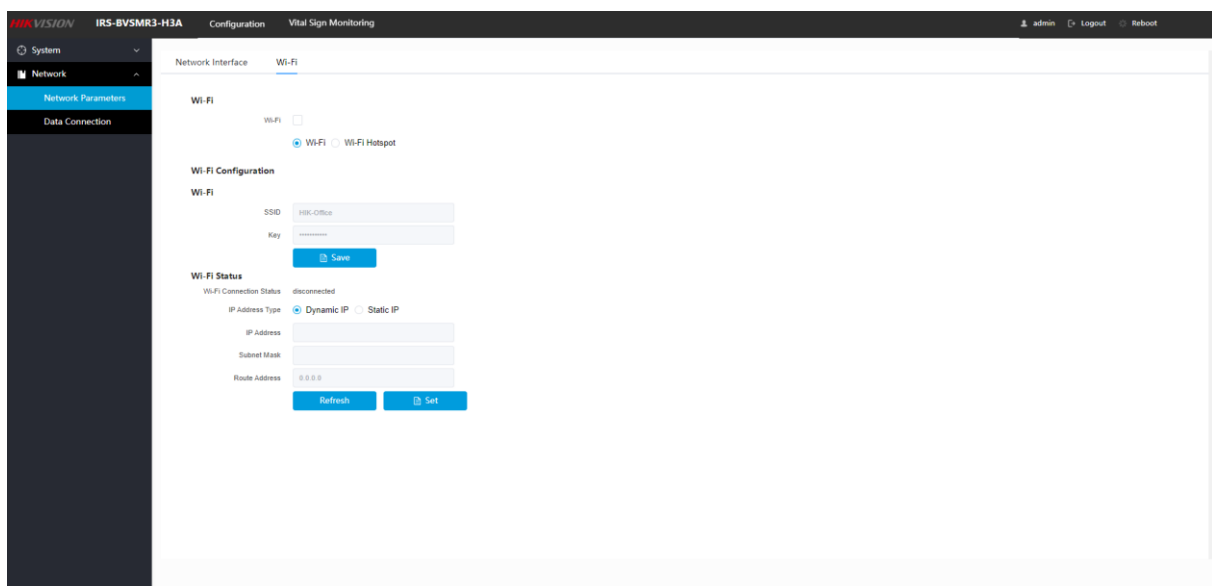

Figure 4-17 Set Wi-Fi

Set Wi-Fi Hotspot

You need to configure Wi-Fi hotspot parameters if the device is used as a hotspot for sharing network with other devices.

Steps

1. Go to **Configuration** → **Network** → **Network Parameters** → **Wi-Fi** for parameter settings.
2. Check **Wi-Fi Hotspot** and enter **SSID** and **Key**, and click **Save**.

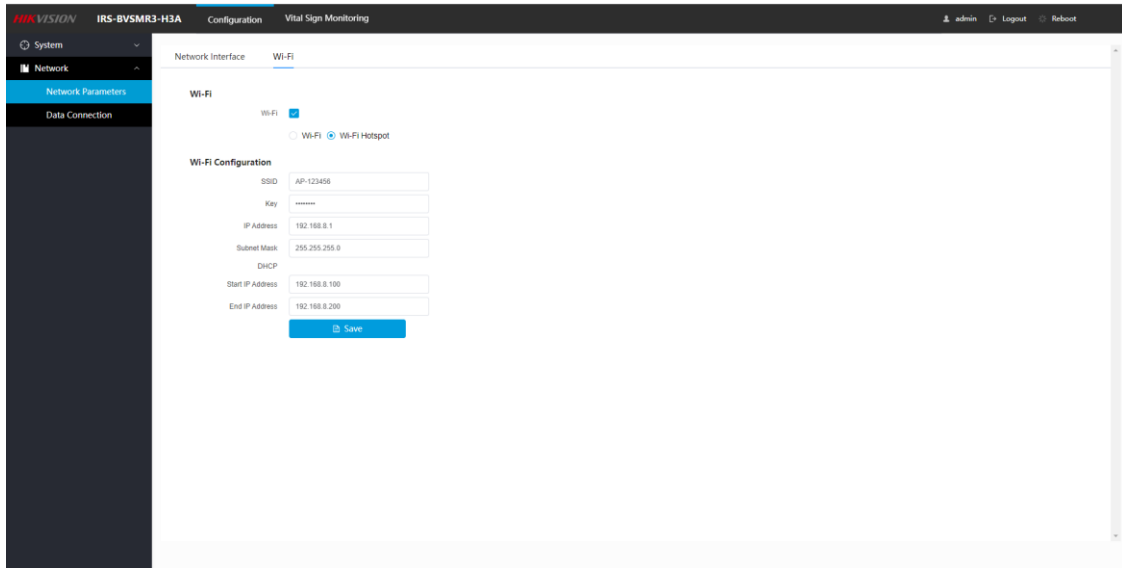

Figure 4-18 Set Wi-Fi Hotspot

4.4 Data Connection Configuration

4.4.1 OTAP

OTAP is a platform access protocol, and when the device needs to forward data through the platform, you can configure OTAP platform.

Before You Start

The platform server has been configured, and the device communicates with the platform network normally.

Steps

1. Go to **Configuration** → **Network** → **Data Connection** → **OTAP** for parameter settings.
2. Check **Enable** and enter **Server IP**, **Server Port**, and **Device ID**.

Note

The device ID is the same as the device ID that is reserved when the device is added to the platform software.

3. Enter **Key** and click **Save**.

Note

The key is the same as added to the platform software.

Auxiliary Care Radar User Manual

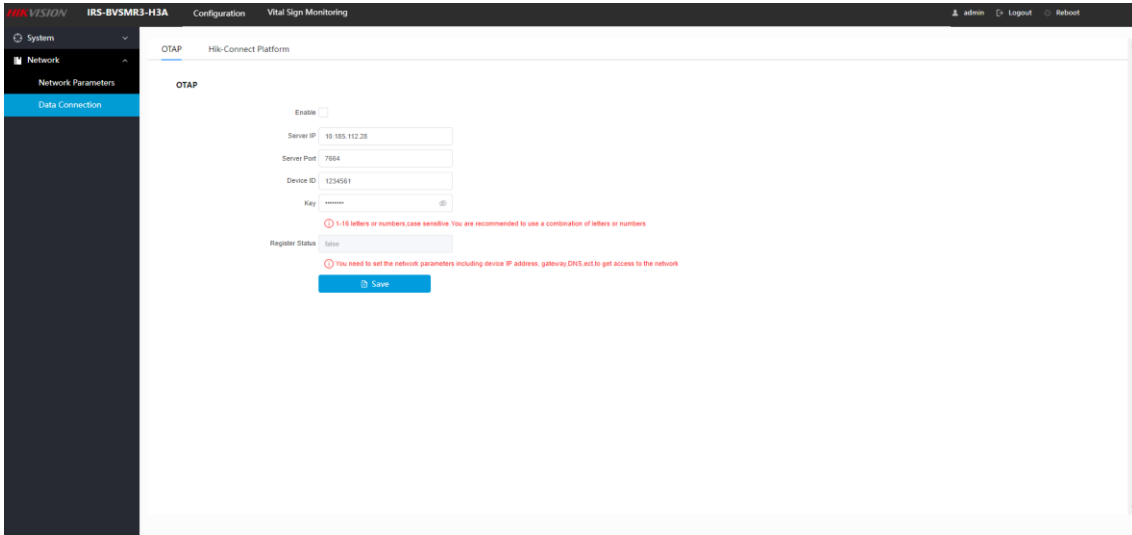

Figure 4-19 Set OTAP

Chapter 5 Device Maintenance

If the device is not working properly, please contact the store where the device is purchased or the nearest service center, do not disassemble or modify the device in any way.

The surface of the device may accumulate dust after long-term use, please power off it before cleaning the surface dust, wipe off the dust with an alcohol cotton or dry rag, and power on again.

Chapter 6 FAQ (Frequently Asked Question)

6.1 Question 1

Q: How to deal with false alarms of abnormal signs?

A: This device is not classified as a medical device and is not intended for clinical or diagnostic use. It is designed solely for general wellness, lifestyle tracking, or recreational purposes. It is not suitable for the prevention, diagnosis, monitoring, treatment, or alleviation of any disease or medical condition. Do not rely on the data provided by this device for medical decisions. Always consult a qualified healthcare professional if you have any concerns about your health.

6.2 Question 2

Q: How does radar detect respiratory rate and heart rate?

A: Radar detects and judges respiratory rate and heart rate by detecting small ups and downs in the chest.

6.3 Question 3

Q: What is the range of respiratory rate and heart rate?

A: The respiratory rate can be measured in a range of 6 to 40 times/min, and the heart rate can be detected in a range of 40 to 120 times/min.

6.4 Question 4

Q: What is the detection error of the radar on the target respiratory rate and heart rate?

A: For normal breathing, the detection error should not exceed every 2 times/minute; For heart rate, the detection error should not exceed 5 to 10 times per minute.

6.5 Question 5

Q: How does body movement work?

A: The auxiliary care radar transmits and receives the velocity information of the target that can be

detected by millimeter waves, and realizes the detection function based on this information.

6.6 Question 6

Q: Will sleeping on one side affect the detection effect?

A: Sleeping on one side has little effect on the detection effect, but the detection effect is better when you are lying on your back.

6.7 Question 7

Q: Will covering the target with a quilt or blanket affect the detection effect?

A: Quilts will not affect the detection effect.

6.8 Question 8

Q: Will some electrical appliances or furniture affect the test?

A: The electronics themselves have no effect on the detection. However, if there are moving or vibrating objects in the detection area (such as the air pump of a medical ventilator, a working electric fan, a shaking curtain, etc.), it can have a significant impact on the detection effectiveness of the device.

6.9 Question 9

Q: Does the presence of multiple people or pets make a difference?

A: Multiple people or pets may cause errors in the data, which will be visually reflected in the waveform.

6.10 Question 10

Q: Does the radar support multi-person detection?

A: Multi-person detection is not supported, and data output will be provided in the case of multiple people, but it is not possible to tell which person is being detected.

6.11 Question 11

Q: Do you have any suggestions on how to install the Assisted Care Radar?

A: It is recommended to install it on the wall near the head of the bed, preferably about 1 m above

the bed surface and facing the center of the bed.

6.11 Question 12

Q: What factors affect the presence of unmanned detection?

A: Regarding the presence of unmanned detection, when a person is within the radar detection range, under normal circumstances, a person can be detected correctly. However, due to individual differences, a very small number of users may be measured as unmanned during normal sleep even when they are in an ideal position within the radar detection range, which may be due to the low breathing and heartbeat amplitude in special attitudes, resulting in the radar not being able to detect the target.

6.13 Question 13

Q: What factors affect body movement testing?

A: Regarding body movement detection, in the laboratory scenario, the average detection rate of radar equipment for normal movements is about 90%, and the detection rate of small movements is low. In the home scene, for the normal range of movement, the radar detection rate of the whole night also exceeded 90%. The detection rate of motor movements is not only related to the magnitude of the motor amplitude, but also related to the motor habits of different individuals, and the detection sensitivity can be set to improve the situation of missed detection of small amplitude movements. If there is a false detection caused by atypical body movements such as deep breathing, the detection sensitivity can also be adjusted to improve the user experience.

6.14 Question 14

Q: What factors affect respiratory heart rate measurement?

A: Due to individual differences, the accuracy of breathing and heartbeat rate measurements will vary from person to person. The actual changes in the respiratory and heartbeat frequency values are fast, and there is a certain delay in the radar test results, which will lead to a certain degree of deviation. Slight movements of the body can cause rapid increases or decreases in breathing and heart rate, and the radar filters out this jitter, causing a certain degree of deviation.



See Far, Go Further